

# 钢丝螺套使用手册



新乡市中冠机械有限公司

## 企业简介

新乡市中冠机械有限公司是从事钢丝螺套产品及配套安装工具研发、制造、销售和服务的专业化生产企业。

公司成员曾参与国家多项重点军工产品研制，在螺套产品的基础研究、新品开发、工艺创新、设备研制、质量控制、市场营销等方面拥有丰富经验；公司可以在用户新产品设计、小批量试制、定型生产等研制生产的各阶段为用户提供钢丝螺套结构及工作原理介绍、规格选型、强度及精度测试、现场使用培训、电动或气动工具大批量安装生产线规划、后期服务维修等方面提供全方位技术支持。

公司注重产品质量，把为客户提供品质一流的产品作为企业的使命，为此建立了严格的质量控制体系，在原材料采购、生产加工、检测入库等产品生产销售的各环节严格管理，确保产品品质达到国外先进水平。目前公司产品为国内外多家大型电子通信设备制造企业、汽车变速箱制造企业及军工科研生产单位配套，品质始终如一，可完全替代进口，赢得了客户的信任。

公司通过了 GB/T19001-2008/ISO9001:2008 质量管理体系审核认证。

公司钢丝螺套生产工艺先进，拥有国内领先的全自动数控绕套机、半自动绕套机（国家发明专利）、精密轧丝机、精密外圆磨、精密螺纹磨、丝锥铲磨、万能工具显微镜、丝材拉力试验机等全套螺套产品、工装、安装工具及检测控制设备，具有年产 2000 万件各种规格公英制螺套和配套安装工具的生产能力。

公司可按照国军标 GJB119. 1A-119. 4A 系列、GJB5107-5110 系列，航空标准 HB6200-6202 系列、HB5513-5516 系列，航天标准 QJ2820-2822、QJ1247 系列，国家标准 GB/T24425. 1-24425. 6 系列、机械部标准 JB/T7604. 1~4-94 系列，以及美国 MS、英国 BS、德国 AS、DIN8140 等多种标准要求生产制造钢丝螺套产品及配套安装工具，也可以根据用户特殊需要，设计制造各种非标准钢丝螺套产品及配套工具。

公司坚持“为客户提供满意产品，与客户共同发展”的经营理念，关注客户利益，致力于为客户创造最大价值，期待与客户共同成长。

公司重承诺、守信用、依法依规、诚信经营，努力成为国内钢丝螺套行业的标杆企业。

我们的产品广泛应用于航空、航天、兵器、电器、仪表、通讯、汽车、矿山冶金、水泵、化纤、化工等行业，我们欢迎各界朋友来电（函）、来人洽谈业务，发展合作。

公司其它产品：高精度金属丝、金属筛网、滤网、滤芯（器）、化纤备件、筛分检具、振动设备。

#### 联系信息

公司名称：新乡市中冠机械有限公司

地址：河南省新乡市新飞大道南段 1018 号新乡科技产业园区 A4a 号

电话：0373—2686995 15837387867

0373—5036376 15517311756

0373—2686996 13937366078

传真：0373—3866533 商务 QQ：3163469217

网址：<http://www.zhongguangongye.com>

E-mail：[xxzg87867@126.com](mailto:xxzg87867@126.com) 3163469217@qq.com

# 目 录

## 一、钢丝螺套简介

- 1、钢丝螺套及应用
- 2、钢丝螺套的分类
- 3、钢丝螺套的特点
- 4、钢丝螺套的材料及适用条件
- 5、钢丝螺套公称长度 L 的选择
- 6、钢丝螺套依据的技术标准
- 7、锁紧型钢丝螺套锁紧力矩技术条件

## 二、钢丝螺套的标记方法

- 1、国家军用标准钢丝螺套标记法
- 2、航空工业标准钢丝螺套标记法
- 3、国家民用标准 GB/T24425.1-2009《普通型钢丝螺套》的标记示例
- 4、国内企业标准生产的钢丝螺套标记法
- 5、国外按标准长度生产的钢丝螺套标记法

## 三、钢丝螺套的结构尺寸及安装参数

- 1、符号说明
- 2、公制系列钢丝螺套结构尺寸及安装参数
- 3、美制粗牙统一螺纹 (UNC) 钢丝螺套结构尺寸及安装参数
- 4、美制细牙统一螺纹 (UNF) 钢丝螺套结构尺寸及安装参数
- 5、英制粗牙惠氏螺纹 (BSW) 钢丝螺套结构尺寸及安装参数
- 6、英制细牙惠氏螺纹 (BSF) 钢丝螺套结构尺寸及安装参数
- 7、英制管螺纹 (G) 钢丝螺套结构尺寸及安装参数
- 8、公制无尾钢丝螺套结构尺寸及安装参数
- 9、美制统一螺纹无尾钢丝螺套结构尺寸及安装参数

## 四、钢丝螺套专用丝锥

## 五、钢丝螺套安装扳手

## 六、钢丝螺套安装柄去除工具

## 七、钢丝螺套拆卸工具

## 八、钢丝螺套专用内螺纹塞规

## 九、钢丝螺套的装配过程

## 一、 钢丝螺套的简介

### 1、 钢丝螺套工作原理

**钢丝螺套**是一种按螺纹基本牙型构成的高强度、高精度、高表面粗糙度的冷轧菱形钢丝绕制而成的螺纹中间连接件。其外形如同弹簧，故又称为弹簧丝套，简称丝套。把绕制成型的钢丝螺套装入零件上特制的螺纹底孔内，螺套由钢丝菱形截面外表面形成的外螺纹依靠螺套径向弹力紧密的贴合在零件内螺纹上，螺套菱形钢丝内表面形成新的标准螺孔，用来拧入螺栓，螺栓拧入螺孔后，螺套的菱形截面镶嵌于零件内螺纹和螺栓外螺纹构成的螺旋槽内，以传递螺栓的轴向力。

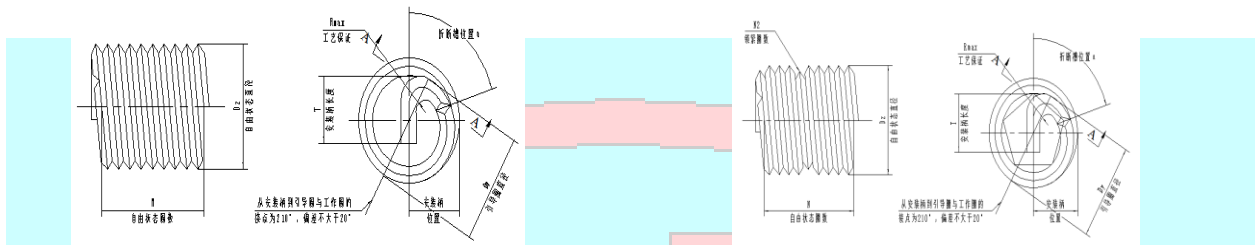

钢丝螺套安装后所形成的内螺纹孔精度取决于钢丝螺套型面制造精度和钢丝螺套安装底孔螺纹加工精度；在国内现有螺套标准中，螺套型面制造精度一般按 5H 和 6H 两种精度等级控制，安装底孔的螺纹加工精度应达到所选用的螺套标准中对安装底孔的精度要求，螺套安装完成后形成的标准螺纹孔对应精度分别为 5H 或 6H；同理英制螺套安装后可形成精度为 3B 或 2B 级的标准螺纹孔。螺套使用单位可根据自身要求选用精度等级不同的产品。

### 2、 钢丝螺套的分类

#### (1) 按构成材料分类

按照制造钢丝螺套所采用的材料，可把钢丝螺套分为**不锈钢螺套**、**铜合金螺套**、**高温合金螺套**等。

#### (2) 按钢丝螺套使用功能分类

##### A、普通型钢丝螺套

普通型钢丝螺套由多圈螺旋线圈组成，通过选用合理的安装长度，在螺钉和基体内螺纹之间形成弹性连接，消除螺纹制造误差，提高连接强度，与传统衬套相比，减少附加体积和重量。

##### B、锁紧型钢丝螺套

由一圈或多圈的多边形非变形圈形成锁紧边，对装配螺钉起到紧固防松作用，并具有普通型螺套的所以特点。

### (3) 按钢丝螺套的旋转方向分类

- A、右旋钢丝螺套
- B、左旋钢丝螺套

### (4) 按钢丝螺套安装柄有无分类

- A、有安装柄钢丝螺套
- B、无安装柄钢丝螺套

### (5) 按钢丝螺套表面有无镀层分类

- A、表面无镀层钢丝螺套
- B、表面有镀层钢丝螺套 如：镀银、镀镉等。

## 3、钢丝螺套的特点

(1) 钢丝螺套在自由状态下外径大于基体螺纹孔内径，依靠自身的弹力可牢固的固定在基体螺纹孔中，不需要采取特殊的锁紧方式，拆装方便，便于修复。同时具有结构紧凑、体积小、重量轻的特点。

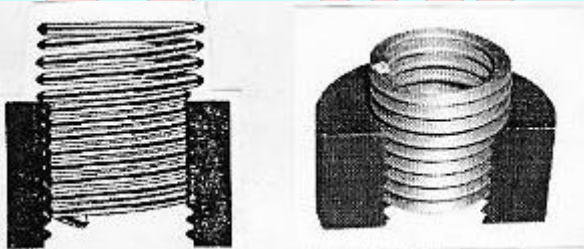

(2) 钢丝螺套由冷轧不锈钢丝绕制而成，强度高，表面质量好，耐磨性好，对基体螺纹有保护作用，可多次反复拆卸不损坏基体螺纹孔。

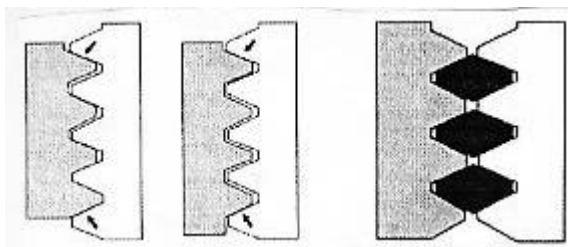

(3) 钢丝螺套装入螺纹底孔后，在螺钉与安装钢丝螺套的内螺纹孔之间形成弹性连接，一定程度上能补偿螺距误差和牙型角误差，可使载荷均匀分布，提高基体螺纹连接强度，延长使用寿命。



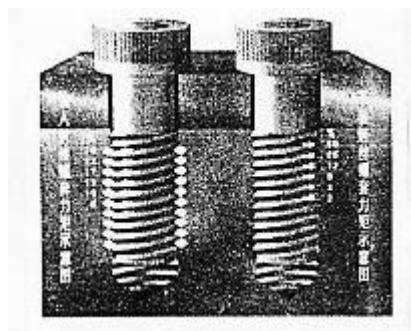

(4) 不锈钢螺套具有优良的抗腐蚀性能，在多种环境条件下使用也不会产生锈蚀和阻滞。

(5) 锁紧型钢丝螺套的锁紧圈具有独特的弹性锁紧边能紧紧的抱住螺栓的螺牙，从而能防止由于振动和撞击产生的松动，并能够允许重复多次拆卸而不丧失其锁紧力，采用锁紧螺套后，螺栓、螺钉可不必再采用其它锁紧装置。

(6) 钢丝螺套可方便、快捷的进行内螺纹孔公↔英制螺纹的转换。

(7) 在出现内螺纹加工错误或需要对已损坏的内螺孔进行修复时，选用钢丝螺套作为修复手段，可以在不改变原工件结构的前提下，获得经济的维修，拯救重要零部件，修复后的内螺纹能够快速恢复到原来的使用状态，达到甚至超过受损前的使用性能。

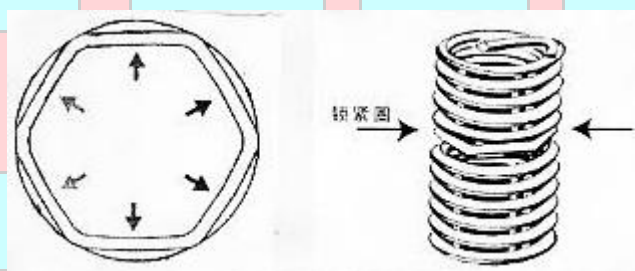

#### 4、钢丝螺套的材料及适用条件

表 (1)

材料	牌号	使用温度	室温下抗拉强度	表面状况
不锈钢	0Cr18Ni9	425℃短时间 315℃长时间	>1400Mpa	无镀层
	1Cr18Ni9			镀镉
	1Cr18Ni9Ti			镀银
铜合金	QSn6.5—4	300℃短时间 250℃长时间	>1000Mpa	无镀层 镀镉
高温合金	Inconelx750	750℃短时间	>1400Mpa	无镀层
	Nimonic90	550℃长时间		镀银

#### 5、钢丝螺套公称长度 L 的选择

钢丝螺套公称长度  $L$ , 也就是基本螺纹孔长度  $l_2$ , 通常按螺纹公称直径  $d$  的倍数来供应, 即  $l_2=0.5d; 0.75d; 1d; 1.25d; 1.5d; 2d; 2.5d; 3d\cdots\cdots$ 。

螺纹公称直径  $d$  也就是装在钢丝螺套中的螺钉公称直径。

用户在选用钢丝螺套公称长度  $L$  时, 应把螺栓作为最弱的连接部分加以考虑。可参照安装钢丝螺套的工件基体材料强度和螺钉性能等级按表 (2) 选用, 使基体、钢丝螺套、螺栓达到最佳强度匹配。

表 (2) 钢丝螺套公称长度  $L$  推荐值

钢丝螺套安装用内螺孔材料抗拉强度 $\sigma_b$ (Mpa)	螺 钉 性 能 等 级						
	3.6	5.8	8.8	9.8	10.9	12.9	14.9
80---150	1.5d	2d	2.5d	2.5d	2.5d	2.5d	3d
150---200	1d	1.5d	2d	2d	2d	2.5d	2.5d
200---250	1d	1.5d	1.5d	1.5d	2d	2.5d	2.5d
250---300	1d	1d	1.5d	1.5d	1.5d	2d	2d
300---400	0.5-1d	1d	1d	1.5d	1.5d	1.5d	2d
>400	0.5-1d	0.5-1d	1d	1d	1.5d	1.5d	1.5d

## 6、钢丝螺套制造验收的技术标准

### (1) 国内军用、民用标准

GJB119. 1A-119. 3A-2001	国家军用标准《普通型钢丝螺套》
GJB119. 1-119. 4-86	国家军用标准《普通型钢丝螺套》(老标)
GJB119. 4A-2001	国家军用标准《普通型钢丝螺套通用规范》
GJB5107-2002	国家军用标准《锁紧型钢丝螺套通用规范》
GJB5108-2002	国家军用标准《钢丝螺套安装要求》
GJB5109-2002	国家军用标准《锁紧型有折断槽钢丝螺套》
GJB5110-2002	国家军用标准《锁紧型无折断槽钢丝螺套》
HB6200-1989	航空工业标准《有折断槽锁紧型钢丝螺套》
HB6201-1989	航空工业标准《无折断槽锁紧型钢丝螺套》
HB6202-1989	航空工业标准《锁紧型钢丝螺套技术条件》
HB5513-1996	航空工业标准《普通型有折断槽钢丝螺套》
HB5514-1996	航空工业标准《普通型无折断槽钢丝螺套》



HB5515-1996	航空工业标准《安装钢丝螺套用内螺纹》
HB5516—1996	航空工业标准《普通型钢丝螺套技术条件》
JB/T7604. 1~4-94	机械工业部标准《锁紧型钢丝螺套》
GB/T24425. 1-2009	国家标准《普通型钢丝螺套》
GB/T24425. 3-2009	国家标准《锁紧型钢丝螺套》
Q/9D204. 1~3-1999	企业标准《普通型螺纹丝套》

### (2) 国外钢丝螺套标准:

NASM122076 系列标准型	- UNC 标准	美军标
NASM124651 系列标准型	- UNF 标准	美军标
NASM21209 自锁型	- UNC 和 UNF 标准	美军标

NASM8846 标准 美军标

BS7751 - 公制 - 粗牙标准 英国国家标准

BS7752 - 公制 - 细牙标准 英国国家标准

BS7753 英国国家标准

MA3279, MA3280, MA3281 - 公制 - 标准型 美国航空标准

MA3329, MA3330, MA3331 - 公制 - 自锁型 美国航空标准

AS6733 系列 - UNF - 无镀层标准

AS8455 系列 - UNF - 镉镀层标准

AGS3600 系列 - UNF - 镀镉 - 自锁型

AGS3700 系列 - Nimonic 合金 90 - 自锁型

LN9499, LN9039 德国航空标准

DIN8140 德国工业标准

### (3) 引用其他标准

△GB196-1981	《普通螺纹 基本尺寸》
△GB197-1981	《普通螺纹 公差与配合》
△HB5829-1983	《普通螺纹收尾、肩距、退刀槽、引导及倒角》
△GB3934-1983	《普通螺纹量规》
△GB/T4240-1993	《不锈钢丝》
△GB/T228-1987	《金属拉伸试验方法》

△GJB715. 3A-2002

《紧固件试验方法 振动》

表(3) 钢丝螺套配套使用螺栓世界各国标准对照表

标准代号 项目名称	LSO (国际)	GB (中国)	ANSI (美国)	BS (英国)	DIN (德国)	Г OCT (俄罗斯)	NF (法国)	JIS (日本)
基本牙型	68-1973	192-81	B1. 13M-79	3643/1-81	13/19-72	9150-81	E03-001-59	B0205-82 B0207-82
米制直径螺矩	261-1973	193-81	B1. 13M-79	3643/1-81	13/12-75	8724-81	E03-003-71	B0205-82 B0207-82
米制选用系列	262-1973	—	B1. 18M-82	3643/1-81	13/13-83	—	E03-014-71	B0205-82 B0207-82
米制基本尺寸	724-1978	196-81	B1. 13M-79	3643/1-63	13/1~ 11-70	3150-81	E03-013-71	B0205-82 B0207-82
米制螺纹公差原理	965/1-1980	197-81	B1. 18M-82	3643/2-81	13/14~ 15-72	16093-70	E03-051~ 052-76	B0215-82
商品螺纹极限尺寸	6965/2-1980	—	B1. 18M-82	—	13/13-83	—	—	B0209-82 B0211-82
推荐公差带偏差表	965/3-1980	2516-81	B1. 18M-82	3643/2~3-67	13/27-73	16093-70	E03-053~ 056-76	—
米制螺纹检验	1502-1978	3934-83	B1. 16M-72	916/3-68	13/16~ 18-71	—	E03-151-70	B0251~ 0252-75
园柱三角螺纹术语	5408-1983	2515-81	B1. 7M-77	2517-60	2244-77	11708-66	—	B0101-74

## 7、锁紧型钢丝螺套锁紧力矩要求

中国航空标准 HB6202-89 《锁紧型钢丝螺套技术条件》(N·m)

规格	最大锁紧力矩	最小锁紧力矩
M3×0.5	0.49	0.07
M4×0.7	0.98	0.15
M5×0.8	1.96	0.25
M6×1	2.94	0.39
M7×1	4.90	0.59
M8×1	6.86	0.74
M8×1.25	6.86	0.78
M10×1	9.31	1.27
M10×1.5	9.31	1.37
M12×1.5	14.71	1.86

## 英国 TS41 《BS HR503 尼莫尼克 90 镀银统一锁紧型钢丝螺套技术说明书》

螺纹名义尺寸	最大锁紧力矩				最小松动力矩	
	室温下力矩试验		高温下力矩试验		室温及高温试验	
	牛顿米	磅英寸	牛顿米	磅英寸	牛顿米	磅英寸
0. 1900-32	1. 92	17	2. 94	26	0. 23	2
0. 2500-28	3. 95	35	6. 78	60	0. 4	3. 5
0. 3125-24	8. 13	72	13. 56	120	0. 73	6. 5
0. 3750-24	10. 85	96	18. 06	160	1. 07	9. 5
0. 4375-20	13. 6	120	22. 6	200	1. 58	14. 0
0. 5000-20	20. 3	180	33. 9	300	2. 03	18. 0
0. 5625-18	27. 1	240	45. 2	400	2. 71	24. 0
0. 6250-18	40. 7	360	67. 8	600	3. 62	32. 0

## 法国 CCT6063 《自锁和非自锁钢丝螺套的验收和合格条件》

直径×螺矩	锁紧力矩 单位: 牛顿米		
	第 1 次拧入时的 最大力矩	第 5 次拧出时的 最小力矩	第 15 次拧出时的 最小力矩
MJ3×0.5	0.7	0.2	0.1
MJ4×0.7	1.1	0.3	0.15
MJ5×0.8	1.9	0.5	0.25
MJ6×1	3.4	0.7	0.35
MJ7×1	5.2	1.1	0.55
MJ8×1	7	1.4	0.7
MJ8×1.25	7	1.4	0.7
MJ10×1.25	11.5	2.3	1.2
MJ10×1.5	11.5	2.3	1.2
MJ12×1.25	17.8	3.5	1.8
MJ12×1.5	17.8	3.5	1.8
MJ14×1.5	24	5	2.5
MJ16×1.5	37	7.5	3.7
MJ18×1.5	53	10.6	5.3

## 二、钢丝螺套标记法

**1、国家军用标准钢丝螺套标记法**（以公称直径 6mm，螺距 1mm，自由状态圈数 8 的螺套为例）：

（1）国军标 GJB119.1A-2001《普通型有折断槽钢丝螺套》的标记示例

无镀层钢丝螺套：6x1x8 GJB119.1A

镀镉钢丝螺套：6x1x8 GJB119.1A-Cd

镀银钢丝螺套：6x1x8 GJB119.1A-Ag

（2）国军标 GJB119.2A-2001《普通型无折断槽钢丝螺套》的标记示例

无镀层钢丝螺套：6x1x8 GJB119.2A

镀镉钢丝螺套：6x1x8 GJB119.2A-Cd

镀银钢丝螺套：6x1x8 GJB119.2A-Ag

（3）国军标 GJB5109-2002《锁紧型有折断槽钢丝螺套》的标记示例

锁紧型有折断槽钢丝螺套：GJB5109-6x1x8

（4）国军标 GJB5110-2002《锁紧型无折断槽钢丝螺套》的标记示例

锁紧型无折断槽钢丝螺套：GJB5110-6x1x8

**2、航空工业标准钢丝螺套标记法**（以公称直径 6mm，螺距 1mm，自由状态圈数 8 的螺套为例）：

（1）航标 HB5513-1996《普通型有折断槽钢丝螺套》的标记示例

无镀层钢丝螺套：HB5513-6x1x8

镀镉钢丝螺套：HB5513-6x1x8Cd

镀银钢丝螺套：HB5513-6x1x8Ag

（2）航标 HB5514-1996《普通型无折断槽钢丝螺套》的标记示例

无镀层钢丝螺套：HB5514-6x1x8

镀镉钢丝螺套：HB5514-6x1x8Cd

镀银钢丝螺套：HB5514-6x1x8Ag

（3）航标 HB6200-89《锁紧型有折断槽钢丝螺套》的标记示例

锁紧型有折断槽钢丝螺套：HB6200-6x1x8

（4）航标 HB6201-89《锁紧型无折断槽钢丝螺套》的标记示例

锁紧型无折断槽钢丝螺套：HB6201-6x1x8

**3、国家民用标准 GB/T24425.1-2009《普通型钢丝螺套》的标记示例**（以公称直径 6mm，螺距 1mm，自由状态圈数 8 的螺套为例）：

带折断槽的普通型钢丝螺套：GB/T24425.1 M6-8

不带折断槽的普通型钢丝螺套：GB/T24425.1 M6-8W

**4、国内企业标准生产的钢丝螺套标记法**（以公称直径 6mm，螺距 1mm，自由状态圈数 8 的螺套为例）：

(1) 普通型有折断槽的钢丝螺套：ST6x1x8k

(2) 普通型无折断槽的钢丝螺套：ST6x1x8

(3) 锁紧型有折断槽钢丝螺套：ZST6x1x8k

(4) 锁紧型无折断槽钢丝螺套：ZST6x1x8

**5、国外按标准长度生产的钢丝螺套标记法**

(1) FR（普通型） Md（直径）×p（螺距）-nd

(2) SL（锁紧型） Md（直径）×p（螺距）-nd

**三、钢丝螺套的型式尺寸的安装参数**

**1、符号说明**

钢丝螺套安装螺孔及装配参数

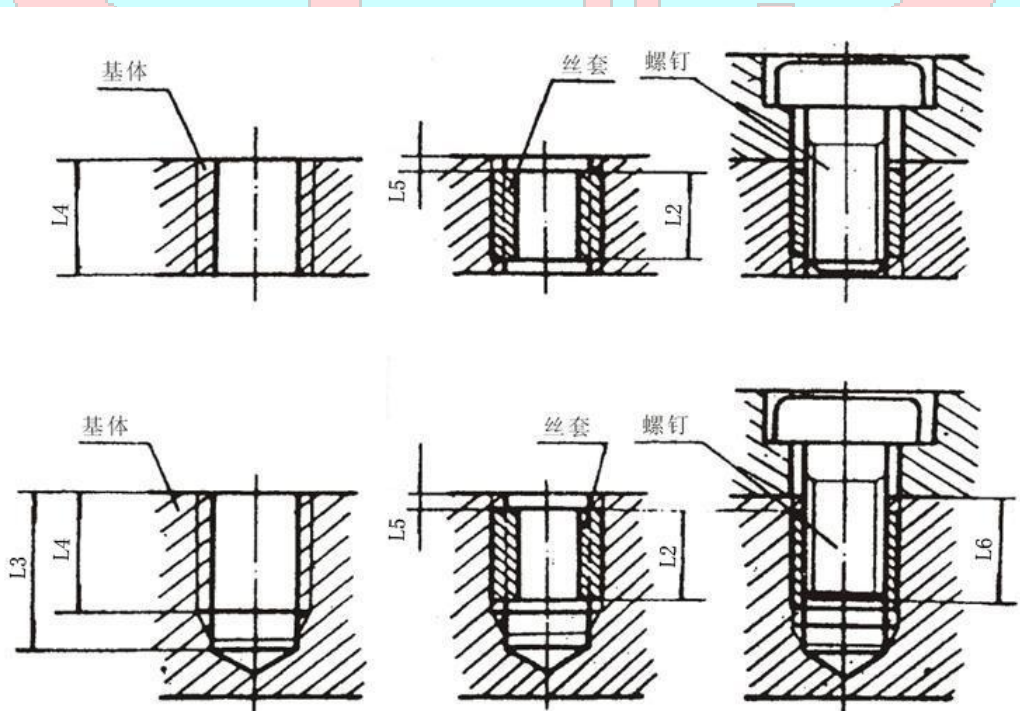

P.....螺距

- w.....钢丝螺套在自由状态下的圈数
- d.....钢丝螺套公称直径（螺钉公称直径）
- D<sub>z</sub>.....钢丝螺套在自由状态下的外径
- d<sub>0</sub>.....钻孔时所选用的钻头直径
- D<sub>s1</sub>.....安装钢丝螺套的底孔小径
- L<sub>1</sub>.....钢丝螺套公称长度
- L<sub>2</sub>.....钢丝螺套安装后去除安装柄时形成的内螺纹深度（同 L<sub>1</sub>）
- L<sub>3</sub>.....钻孔深度
- L<sub>4</sub>.....安装钢丝螺套用内螺纹孔螺纹深度（不小于 L<sub>1</sub>）
- L<sub>5</sub>.....钢丝螺套距安装表面的间距（L<sub>5</sub>=0.5P±0.25P）
- L<sub>6</sub>.....未去除安装柄时，螺栓最大拧入深度

## 2、公制系列钢丝螺套结构尺寸及安装参数

表（4） 公制系列钢丝螺套结构尺寸及安装参数表

公称直径 (d)	螺距 (P)	公称长度		圈数 (W)	自由状态 下外径 (Dz) Min. Max.	安装螺 套的螺 纹底孔 小径 (D <sub>s1</sub> ) Min. Max.	推荐 钻头 直径 (d <sub>0</sub> )	钻孔 深度 (L <sub>3</sub> )	未去除 安装柄 时螺栓 最大拧 入深度 (L <sub>6</sub> )
		xd	L <sub>1</sub>						
1.6	0.35	1d	1.6	3.2	2.13 2.28	1.65 1.8	1.7	3.2	1.5
		1.5d	2.4	4.8				4.0	2.2
		2d	3.2	6.4				4.8	3.0
2	0.4	1d	2.0	2.9	2.60 2.8	2.09 2.18	2.1	3.6	1.8
		1.5d	3.0	4.9				4.6	2.8
		2d	4.0	6.9				5.6	3.8
		2.5d	5.0	8.9				6.6	4.8
		3d	6.0	10.9				7.6	5.8
2.5	0.45	1d	2.5	3.5	3.30 3.50	2.60 2.70	2.6	4.3	2.3
		1.5d	3.75	5.9				5.6	3.5
		2d	5.0	8.1				6.8	4.8
		2.5d	6.25	10.5				8.1	6.0
		3d	7.5	12.9				9.3	7.3



3	0.5	1d	3.0	3.9	3.80 4.00	3.11 3.22	3.1	5.0	2.7
		1.5d	4.5	6.3				6.5	4.2
		2d	6.0	8.7				8.0	5.7
		2.5d	7.5	11.1				9.5	7.2
		3d	9.0	13.5				11.0	8.7
3.5	0.6	1d	3.5	3.7	4.42 4.60	3.63 3.76	3.7	5.9	3.2
		1.5d	5.25	6.3				7.65	5.0
		2d	7.0	8.7				9.4	6.7
		2.5d	8.75	11.2				11.15	8.5
		3d	10.5	13.3				12.9	10.2
4	0.7	1d	4.0	3.7	5.05 5.25	4.15 4.29	4.2	6.8	3.6
		1.5d	6.0	6.1				8.8	5.6
		2d	8.0	8.4				10.8	7.6
		2.5d	10.0	10.9				12.8	9.6
		3d	12.0	13.2				14.8	11.6
5	0.8	1d	5.0	4.3	6.35 6.60	5.17 5.33	5.2	8.2	4.6
		1.5d	7.5	6.9				10.7	7.1
		2d	10.0	9.7				13.2	9.6
		2.5d	12.5	12.3				15.7	12.1
		3d	15.0	14.8				18.2	14.6
6	1	1d	6.0	4.2	7.60 7.85	6.22 6.41	6.3	10.0	5.5
		1.5d	9.0	6.9				13.0	8.5
		2d	12.0	9.6				16.0	11.5
		2.5d	15.0	12.3				19.0	14.5
		3d	18.0	14.6				22.0	17.5
7	1	1d	7.0	5.3	8.65 8.90	7.22 7.41	7.3	11.0	6.05
		1.5d	10.5	8.2				14.5	10.0
		2d	14.0	11.1				18.0	13.5
		2.5d	17.5	14.3				21.5	17
		3d	21.0	17.4				25.5	19.5
8	1.25	1d	8.0	4.7	9.85 10.10	8.27 8.48	8.3	13.0	7.4
		1.5d	12.0	7.4				17.0	11.4
		2d	16.0	10.6				21.0	15.4
		2.5d	20.0	13.5				25.0	19.4
		3d	24.0	16.4				29.0	23.4

8	1	1d	8.0	6.1	9.85 10.10	8.22 8.41	8.3	12.0	7.5
		1.5d	12.0	9.5				16.0	11.5
		2d	16.0	12.9				20.0	15.5
		2.5d	20.0	16.5				24.0	19.5
		3d	24	19.9				28.0	23.5
9	1.25	1d	9.0	5.3	10.85 11.1	9.27 9.48	9.3	14.0	8.4
		1.5d	13.5	8.6				18.5	12.9
		2d	18.0	11.9				23.0	17.4
		2.5d	22.5	15.3				27.5	21.9
		3d	27.0	18.1				32.0	26.4
10	1.5	1d	10.0	5.0	12.10 12.50	10.32 10.56	10.4	16.0	9.2
		1.5d	15.0	8.1				21.0	14.2
		2d	20.0	11.2				26.0	19.2
		2.5d	25.0	14.2				31.0	24.2
		3d	30.0	17.2				36.0	29.2
10	1.25	1d	10.0	6.0	12.10 12.50	10.27 10.48	10.3	15.0	9.4
		1.5d	15.0	9.7				20.0	14.2
		2d	20.0	13.1				25.0	19.4
		2.5d	25.0	16.9				30.0	24.4
		3d	30.0	20.1				35.0	29.4
10	1	1d	10.0	7.6	12.10 12.50	10.22 10.41	10.25	14.0	9.5
		1.5d	15.0	12.1				19.0	14.5
		2d	20.0	16.3				24.0	19.5
		2.5d	25	20.7				29.0	24.5
		3d	30	25.0				34.0	29.5
11	1.5	1d	11.0	5.6	13.10 13.50	11.33 11.56	11.4	17.0	10.2
		1.5d	16.5	9.0				22.5	15.7
		2d	22.0	12.3				28.0	21.2
		2.5d	27.5	15.7				33.5	26.7
		3d	33.0	19.1				39.0	32.2
12	1.75	1d	12.0	5.2	14.40 14.80	12.38 12.64	12.4	19.0	11.1
		1.5d	18.0	8.4				25.0	17.1
		2d	24.0	11.7				31.0	23.1
		2.5d	32.0	14.7				39.0	31.1
		3d	36.0	18.0				43.0	35.1
12	1.5	1d	12.0	6.2	14.40	12.32	12.4	18.0	11.2

		1.5d	18.0	9.8	14.80	12.56		24.0	17.2
		2d	24.0	13.5				30.0	23.2
		2.5d	32.0	17.1				38.0	31.2
		3d	36.0	20.8				42.0	35.2
12	1.25	1d	12.0	7.4	14.40 14.80	12.27 12.48	12.3	17.0	11.4
		1.5d	18.0	11.6				23.0	17.4
		2d	24.0	15.9				29.0	23.4
		2.5d	30.0	20.0				35.0	29.4
		3d	36.0	24.3				41.0	35.4
12	1	1d	12.0	9.3	14.40 14.80	12.22 12.41	12.25	16.0	11.5
		1.5d	18.0	14.5				22.0	17.5
		2d	24.0	19.5				28.0	23.5
		2.5d	30.0	24.8				34.0	29.5
		3d	36.0	30.0				40.0	35.5
13	1.25	1d	13.0	8.2	15.80 16.30	13.27 13.48	13.3	18.0	12.4
		1.5d	19.5	12.7				24.5	18.9
		2d	26.0	17.2				31.0	25.4
14	2	1d	14.0	5.6	16.80 17.20	14.43 14.73	14.5	22.0	13.0
		1.5d	21.0	8.8				29.0	20.0
		2d	28.0	12.0				36.0	27.0
		2.5d	35.0	15.2				43.0	34.0
14	1.5	1d	14.0	7.4	16.80 17.20	14.38 14.56	14.4	20.0	13.2
		1.5d	21.0	11.6				27.0	20.2
		2d	28.0	15.7				34.0	27.2
		2.5d	35.0	19.9				41.0	34.2
14	1.25 火花 塞螺 纹	1d	8.4	4.6	16.80 17.20	14.27 14.48	14.3	13.4	7.8
		1.5d	12.4	7.4				17.4	11.8
		2d	14.4	9.1				19.4	13.8
		2.5d	16.4	10.2				21.4	15.8
14	1	1d	14.0	11.2	16.80 17.20	14.22 14.41	14.25	18.0	13.5
		1.5d	21.0	17.2				25.0	20.5
		2d	28.0	23.2				32.0	27.5
		2.5d	35.0	29.2				39.0	34.5

16	2	1d	16.0	6.5	19.00 19.40	16.43 16.73	16.5	24.0	15.0
		1.5d	24.0	10.1				32.0	23.0
		2d	32.0	13.8				40.0	31.0
		2.5d	40.0	17.5				48.0	39.0
16	1.5	0.75d	12.0	6.1	19.00 19.40	16.32 16.56	16.4	18.0	11.2
		1d	16.0	8.7				22.0	15.2
		1.5d	24.0	13.4				30.0	23.2
		2d	32.0	18.1				38.0	31.2
		2.5d	40.0	22.9				46.0	39.2
18	2.5	0.75d	13.5	3.8	21.50 22.0	18.54 18.90	18.7	23.5	12.2
		1d	18.0	5.6				28.0	16.7
		1.5d	27.0	9.0				37.0	25.7
		2d	36.0	12.3				46.0	34.7
18	2	0.75d	13.5	5.1	21.50 22.0	18.43 18.72	18.5	21.5	12.5
		1d	18.0	7.1				26.0	17.0
		1.5d	27.0	11.2				35.0	26.0
		2d	36.0	15.1				44.0	35.0
18	1.5	0.5d	9.0	4.2	21.50 22.0	18.32 18.56	18.4	15.0	8.2
		0.75d	13.5	7.0				19.5	12.7
		1d	18.0	9.5				24.0	17.3
		1.5d	27.0	14.9				33.0	26.2
		2d	36.0	20.2				42.0	35.2
20	2.5	0.5d	10.0	2.7	23.70 24.20	20.54 20.9	20.7	20.0	8.7
		0.75d	15.0	4.5				25.0	13.7
		1d	20.0	6.3				30.0	18.7
		1.5d	30.0	10.0				40.0	28.7
		2d	40.0	13.7				50.0	38.7
20	2	0.5d	10.0	3.5	23.70 24.20	20.43 20.73	20.5	18.0	9.0
		0.75d	15.0	5.8				23.0	14.0
		1d	20.0	8.0				28.0	19.0
		1.5d	30.0	12.5				38.0	29.0
		2d	40.0	16.8				48.0	39.0
20	1.5	0.5d	10.0	4.9	23.70 24.20	20.32 20.56	20.4	16.0	9.2
		0.75d	15.0	7.9				21.0	14.2
		1d	20.0	10.7				26.0	19.2
		1.5d	30.0	16.7				36.0	29.2
		2d	40.0	22.4				46.0	39.2

22	2.5	0.5d	11.0	3.0	26.30 26.80	22.54 22.90	22.7	21.0	9.7
		0.75d	16.5	5.0				26.5	15.2
		1d	22.0	6.9				32.0	20.7
		1.5d	33.0	10.9				43.0	31.7
		2d	44.0	15.0				54.0	42.7
22	2	0.5d	11.0	3.9	26.30 26.80	22.43 22.73	22.5	19.0	10.0
		0.75d	16.5	6.4				24.5	15.5
		1d	22.0	8.7				30.0	21.0
		1.5d	33.0	13.6				41.0	32.0
		2d	44.0	18.4				52.0	43.0
22	1.5	0.5d	11.0	5.5	26.30 26.80	22.32 22.56	22.4	17.0	10.2
		0.75d	16.5	8.6				22.5	15.7
		1d	22.0	11.7				28.0	21.2
		1.5d	33.0	18.1				39.0	32.2
		2d	44.0	24.5				50.0	43.2
24	3	0.75d	18.0	4.5	28.6 29.1	24.65 25.05	24.8	30.0	16.5
		1d	24.0	6.2				36.0	22.5
		1.5d	36.0	10.0				48.0	34.5
		2d	48.0	14.0				60.0	46.5
24	2	0.5d	12.0	4.3	28.6 29.1	24.43 24.73	24.5	20.0	11.0
		0.75d	18.0	7.0				26.0	17.0
		1d	24.0	9.6				32.0	23.0
		1.5d	36.0	15.0				44.0	35.0
		2d	48.0	20.2				56.0	47.0
24	1.5	0.5d	12.0	6.0	28.6 29.1	24.33 24.56	24.4	18.0	11.2
		0.75d	18.0	9.5				24.0	17.2
		1d	24.0	12.9				30.0	23.2
		1.5d	36.0	19.8				42.0	35.2
		2d	48.0	26.7				54.0	47.2
26	1.5	0.5d	13.0	6.5	31.00 31.50	26.33 26.56	26.4	19.0	12.2
		0.75d	19.5	10.3				25.5	18.7
		1d	26.0	14.0				32.0	25.2
		1.5d	39.0	21.6				45.0	38.2
		2d	52.0	29.1				58.0	51.2
27	3	0.75d	20.3	5.0	32.20 32.70	27.65 28.05	27.8	32.3	18.8
		1d	27.0	7.1				39.0	25.5
		1.5d	40.5	11.4				52.5	39.0

		2d	54.0	15.4				66.0	52.5
		2.5d	67.5	19.5				79.5	66
27	2	0.5d	13.5	5.1	32.20 32.70	27.43 27.73	27.5	21.5	12.5
		0.75d	20.3	7.9				28.3	19.3
		1d	27.0	10.8				35.0	26.0
		1.5d	40.5	16.8				48.5	39.5
		2d	54.0	22.6				62.0	53.0
27	1.5	0.5d	13.5	6.7	32.20 32.70	27.33 27.56	27.4	19.5	12.7
		0.75d	20.3	10.7				26.3	19.5
		1d	27.0	14.6				33.0	26.2
		1.5d	40.5	22.6				46.5	39.7
		2d	54.0	30.0				60.0	53.2
28	1.5	0.5d	14.0	7.1	33.10 33.60	28.33 28.56	28.4	20.0	13.2
		0.75d	21.0	11.1				27.0	20.2
		1d	28.0	15.2				34.0	27.2
		1.5d	42.0	23.3				48.0	41.2
		2d	56.0	31.4				62.0	54.2
30	3.5	0.75d	22.5	4.9	35.20 35.70	30.76 31.21	30.9	36.5	20.7
		1d	30.0	7.0				44.0	28.2
		1.5d	45.0	11.0				59.0	43.2
		2d	60.0	14.9				74.0	58.2
30	2	0.5d	15.0	5.7	35.20 35.70	30.43 30.73	30.5	23.0	14.0
		0.75d	22.5	9.0				30.5	21.5
		1d	30.0	12.3				38.0	29.0
		1.5d	45.0	19.0				53.0	44.0
		2d	60.0	25.5				68.0	59.0
30	1.5	0.5d	15.0	7.8	35.20 35.70	30.33 30.56	30.4	21.0	14.2
		0.75d	22.5	12.2				28.5	21.7
		1d	30.0	16.5				36.0	29.2
		1.5d	45.0	25.3				51.0	44.2
		2d	60.0	34.0				66.0	59.2



33	3.5	0.75d	24.8	5.6	38.30 38.80	33.76 34.21	33.9	38.8	23
		1d	33.0	7.8				47.0	31.2
		1.5d	49.5	12.2				63.5	47.2
		2d	66.0	16.5				80.0	64.2
33	2	0.5d	16.5	6.4	38.30 38.80	33.43 33.73	33.5	24.5	15.5
		0.75d	24.8	10.1				32.8	23.8
		1d	33.0	13.7				41.0	32.0
		1.5d	49.5	21.2				57.5	48.5
		2d	66.0	28.4				74.0	65.0
33	1.5	0.5d	16.5	8.9	38.30 38.80	33.33 33.56	33.4	22.5	15.7
		0.75d	24.8	13.8				30.8	24
		1d	33.0	18.3				39.0	32.2
		1.5d	49.5	28				55.5	48.7
36	4	0.75d	27.0	5.0	42.10 42.60	36.87 37.34	37.0	43.0	25.0
		1d	36.0	7.0				52.0	34.0
		1.5d	54.0	11.1				70.0	52.0
		2d	72.0	15.2				88.0	70.0
36	3	0.5d	18.0	4.4	42.10 42.60	36.65 37.05	36.8	30.0	16.2
		0.75d	27.0	7.2				39.0	25.2
		1d	36.0	9.9				48.0	34.2
		1.5d	54.0	15.3				66.0	52.2
		2d	72.0	20.5				84.0	70.2
36	2	0.5d	18.0	6.8	42.10 42.60	36.43 36.73	36.5	26.0	17.0
		0.75d	27.0	10.3				35.0	26.0
		1d	36.0	14.1				44.0	35.0
		1.5d	54.0	21.9				62.0	53.0
		2d	72.0	31.1				80.0	71.0
36	1.5	0.5d	18.0	9.5	42.10 42.60	36.33 36.56	36.4	24.0	17.2
		0.75d	27.0	14.7				33.0	26.2
		1d	36.0	19.9				42.0	35.2
		1.5d	54.0	30.5				60.0	53.2
		2d	72.0	41.0				78.0	71.2
39	4	0.75d	29.3	5.5	45.10 45.60	39.87 40.34	40.00	45.3	27.3
		1d	39.0	7.7				55.0	37.0
		1.25d	48.8	9.9				64.8	46.8
		1.5d	58.5	12.3				74.5	56.5

		2d	78.0	16.6				94.0	76.0
39	3	0.5d	19.5	4.9	45.10 45.60	39.65 40.05	40.00	31.5	17.7
		0.75d	29.3	7.8				41.3	27.5
		1d	39.0	10.8				51.0	37.2
		1.25d	48.8	13.7				60.8	47.0
		1.5d	58.5	16.8				70.5	56.7
39	2	0.5d	19.5	7.5	45.10 45.60	39.43 39.73	39.5	27.5	18.5
		0.75d	29.3	11.9				37.3	28.3
		1d	39.0	16.3				47.0	38.0
		1.25d	48.8	20.6				56.8	47.8
		1.5d	58.5	25.0				66.5	57.5
42	3	0.5d	21.0	6	48.0 48.5	42.65 43.05	42.8	33.0	19.2
		0.75d	31.5	9				43.5	29.7
		1d	42.0	12				54.0	40.2
		1.5d	63.0	18.3				75.0	61.2
42	1.5	0.5d	21.0	12	48.0 48.5	42.33 42.56	42.4	27.0	20.2
		0.75d	31.5	18.3				37.5	30.7
		1d	42.0	24.5				48.0	41.2
		1.5d	63.0	36.5				69.0	62.2
48	3	0.5d	24.0	6.2	55.0 55.5	48.65 49.05	48.8	36.0	22.2
		0.75d	36.0	9.9				48.0	34.2
		1d	48.0	13.6				60.0	46.2
		1.5d	72.0	20				84.0	70.2
56	4	0.5d	28.0	5.4	64.0 65.0	56.87 57.34	57	44.0	26.0
		0.75d	42.0	8.6				58.0	40.0
		1d	56.0	11.8				72.0	54.0
		1.5d	84.0	18				100.0	82.0
60	3	0.5d	30.0	7.9	69.0 70.0	60.65 61.05	60.8	42.0	28.2
		0.75d	45.0	12.4				57.0	43.2
		1d	60.0	16.9				72.0	58.2
		1.5d	90.0	25.9				102.0	88.2
60	4	0.5d	30.0	5.8	69.0 70.0	60.87 61.34	61	46.0	28.0
		0.75d	45.0	9.2				61.0	43.0
		1d	60.0	12.6				76.0	58.0

		1.5d	90.0	19.5			106.0	88.0
--	--	------	------	------	--	--	-------	------

### 3、美制粗牙统一螺纹（UNC）钢丝螺套结构尺寸及安装参数

表（5）美制粗牙统一螺纹（UNC）

螺纹规格 $d \times p$	螺距 P	螺纹公称长度		圈数 (W)	自由状态 下外径(Dz) Min Max	安装螺 套的螺 纹底孔 小径 (Ds1) Min. Max.	推荐 钻头 直径 (do)	钻孔 深度 (L3)	未去除 安装柄 时螺栓 最大拧 入深度 (L6)
		$\times d$	L1						
2-56 (0.086)	0.435	1d	2.2	3.0	2.7 2.9	2.28 2.44	2.4	3.9	1.8
		1.5d	3.3	5.25				5.0	2.9
		2d	4.4	7.4				6.1	3.9
		2.5d	5.5	9.6				7.2	5.0
4-40 (0.112)	0.635	1d	2.9	2.8	3.6 4.0	3.0 3.15	3.1	5.4	2.5
		1.5d	4.3	4.8				6.8	3.9
		2d	5.8	6.8				8.3	5.4
		2.5d	7.2	8.8				9.7	6.8
5-40 (0.125)	0.635	1d	3.2	3.3	4.0 4.4	3.33 3.48	3.4	5.7	2.8
		1.5d	4.8	5.5				7.3	4.3
		2d	6.4	7.8				8.9	6.0
		2.5d	7.9	10.0				10.4	7.5
6-32 (0.138)	0.794	1d	3.5	2.8	4.5 4.9	3.68 3.89	3.8	6.7	3.1
		1.5d	5.3	4.8				8.5	4.9
		2d	7.0	6.7				10.2	6.6
		2.5d	8.3	8.7				11.5	8.4
8-32 (0.164)	0.794	1d	4.2	3.5	5.2 5.6	4.34 4.52	4.4	7.4	3.8
		1.5d	6.3	5.9				9.5	5.9
		2d	8.3	8.3				11.5	8.0
		2.5d	10.5	10.7				13.7	10.1
10-24 (0.190)	1.058	1d	4.8	2.9	6.2 6.6	5.06 5.28	5.2	9.0	4.3
		1.5d	7.2	5.0				11.4	6.7
		2d	9.6	7.1				13.8	9.1
		2.5d	12.1	9.2				16.3	11.6
12-24 (0.216)	1.058	1d	5.5	3.5	6.8 7.2	5.72 5.92	5.8	9.7	5.0
		1.5d	8.2	5.9				12.4	7.7
		2d	11	8.3				15.2	10.5
		2.5d	13.7	10.7				17.9	13.2
1/4"-20	1.27	1d	6.4	3.4	8.0 8.4	6.62 6.86	6.7	11.5	5.8
		1.5d	9.5	5.7				14.6	8.9
		2d	12.7	8.0				17.8	12.1

		2.5d	15.9	10.3				21.0	15.3		
5/16"-18	1.411	1d	7.9	4.0	9.7	8.24	8.4	13.5	7.2		
		1.5d	11.9	6.6				17.5	11.2		
		2d	15.9	9.3				10.2	8.49	21.5	15.2
		2.5d	19.8	11.9				25.4	19.1		
3/8"-16	1.588	1d	9.5	4.4	11.5	9.89	10	15.9	8.7		
		1.5d	14.3	7.2				12.0	10.12	20.7	13.5
		2d	19.1	10.1				25.5	18.3		
		2.5d	23.8	12.9				30.2	23.0		
7/16"-14	1.814	1d	11.1	4.5	13.4	11.51	11.6	18.4	10.2		
		1.5d	16.7	7.4				14.0	11.78	24.0	15.8
		2d	22.2	10.3				29.5	21.3		
		2.5d	27.8	13.1				35.1	26.9		
1/2"-13	1.954	1d	12.7	4.8	15.2	13.12	13.2	20.5	11.7		
		1.5d	19.1	7.9				15.8	13.40	26.9	18.1
		2d	25.4	10.9				33.2	24.4		
		2.5d	31.8	13.9				39.6	30.8		
9/16"-12	2.117	1d	14.3	5.1	17.0	14.75	14.9	22.8	13.2		
		1.5d	21.5	8.3				17.6	15.03	30.0	20.4
		2d	28.6	11.5				37.1	27.5		
		2.5d	35.7	14.7				44.2	34.6		
5/8"-11	2.309	1d	15.9	5.3	18.9	16.38	16.6	25.1	14.7		
		1.5d	23.8	8.3				19.5	16.68	33.0	22.6
		2d	31.8	11.8				41.0	30.6		
		2.5d	39.7	15.0				48.9	38.5		
3/4"-10	2.54	1d	19.1	5.9	22.4	19.6	19.7	29.3	17.8		
		1.5d	28.6	9.4				23.0	19.91	38.8	27.3
		2d	38.1	13.0				48.3	36.8		
		2.5d	47.6	16.6				57.8	46.3		
7/8"-9	2.822	1d	22.2	6.3	26.0	22.84	23	33.5	20.8		
		1.5d	33.3	10.0				26.7	23.18	44.6	31.9
		2d	44.5	13.7				55.8	43.1		
		2.5d	55.6	17.4				66.9	54.2		
1"-8	3.175	1d	25.4	6.4	29.6	26.09	26.2	38.1	23.8		
		1.5d	38.1	10.2				30.4	26.47	50.8	36.5
		2d	50.8	14.0				63.5	49.2		
		2.5d	63.5	17.8				76.2	61.9		
1 1/8"-7	3.629	1d	28.6	6.3	33.4	29.36	29.5	43.1	26.8		
		1.5d	42.9	10.0				34.4	29.74	57.4	41.1
		2d	57.2	13.8				71.7	55.4		
1 1/4"-7	3.629	1d	31.8	7.1	36.7	32.54	33	46.3	30.0		
		1.5d	47.6	11.3				37.7	32.92	62.1	45.8
		2d	63.5	15.4				78.0	61.7		
1 3/8"-6	4.234	1d	34.9	6.6	40.6	35.84	36	51.8	32.8		

		1.5d	52.4	10.6	41.7	36.35		69.3	50.3
		2d	69.9	14.4				86.8	67.8
1 1/2"-6	4.234	1d	38.1	7.4	43.9	39.02	39.5	55.0	36.0
		1.5d	57.2	11.6				74.1	55.1
		2d	76.2	15.9	45.0	39.53		93.1	74.1

#### 4、美制细牙统一螺纹 (UNF) 钢丝螺套结构尺寸及安装参数

表 (6) 美制细牙统一螺纹 (UNF)

螺纹规格 d×p	螺距 P	螺纹公称长度		圈数 (W)	自由状态 下外径(Dz) Min Max	安装螺 套的螺 纹底孔 小径 (Ds1) Min. Max.	推荐 钻头 直径 (do)	钻孔 深度 (L3)	未去除安 装柄时螺 栓最大拧 入深度 (L6)
		×d	L1						
4-48 (0.112)	0.529	1d	2.8	3.4	3.7	2.97	3	4.9	2.5
		1.5d	4.3	5.6				6.4	4.0
		2d	5.7	7.9	4.1	3.12		7.8	5.4
		2.5d	7.1	10.3				9.2	6.7
6-40 (0.138)	0.635	1d	3.5	3.6	4.5	3.66	3.8	6.0	3.1
		1.5d	5.3	6.0				4.9	3.81
		2d	7.0	8.4				9.5	6.6
		2.5d	8.8	10.8				11.3	8.4
8-36 (0.164)	0.706	1d	4.2	4.0	5.3	4.32	4.4	7.0	3.8
		1.5d	6.3	6.6				5.7	4.47
		2d	8.3	9.1				11.1	7.9
		2.5d	10.5	11.7				13.3	10.1
10-32 (0.190)	0.794	1d	4.8	4.1	6.1	5.0	5.1	8.0	4.4
		1.5d	7.2	6.8				6.5	5.16
		2d	9.6	9.5				12.8	9.2
		2.5d	12.1	12.1				15.3	11.7
1/4"-28	0.907	1d	6.4	5.0	7.8	6.55	6.7	10.0	5.9
		1.5d	9.5	8.1				8.3	6.72
		2d	12.7	11.3				16.3	12.2
		2.5d	15.9	14.4				19.5	15.4
5/16"-24	1.058	1d	7.9	5.5	9.7	8.17	8.2	12.1	7.4
		1.5d	11.9	8.9				10.2	8.35
		2d	15.9	12.2				20.1	15.4
		2.5d	19.8	15.6				24.0	19.3
3/8"-24	1.058	1d	9.5	6.9	11.4	9.75	9.8	13.7	9.0
		1.5d	14.3	10.9				11.9	9.93
		2d	19.1	14.9				23.3	18.6
		2.5d	23.8	19.0				28.0	23.3
7/16"-20	1.27	1d	11.1	6.6	13.4	11.39	11.5	16.2	10.5

		1.5d	16.7	10.6	13.9	11.59		21.8	16.1
		2d	22.2	14.5				27.3	21.6
		2.5d	27.8	18.4				32.9	27.2
1/2"-20	1.27	1d	12.7	7.8			13.1	17.8	12.1
		1.5d	19.1	12.3	15.1	12.97		24.2	18.5
		2d	25.4	16.8	15.7	13.16		30.5	24.8
		2.5d	31.8	21.3				36.9	31.2
9/16"-18	1.411	1d	14.3	7.9			14.7	19.9	13.6
		1.5d	21.5	12.5	16.9	14.59		27.1	20.8
		2d	28.6	17.1	17.6	14.79		34.2	27.9
		2.5d	35.7	21.6				41.3	35.0
5/8"-18	1.411	1d	15.9	8.9			16.3	21.5	15.2
		1.5d	23.8	14.1	18.6	16.18		29.4	23.1
		2d	31.8	19.1	19.3	16.38		37.4	31.1
		2.5d	39.7	24.3				45.3	39.0
3/4"-16	1.588	1d	19.1	9.7			19.5	25.5	18.3
		1.5d	28.6	15.1	22.2	19.39		35.0	27.8
		2d	38.1	20.6	22.9	19.6		44.5	37.3
		2.5d	47.7	26.0				54.1	46.9
7/8"-14	1.814	1d	22.2	9.9			22.7	29.5	21.3
		1.5d	33.3	15.4	26.0	22.62		40.6	32.4
		2d	44.5	21.0	26.7	22.84		51.8	43.6
		2.5d	55.6	26.6				62.9	54.7
1"-14	1.814	1d	25.4	11.5			26	32.7	24.5
		1.5d	38.1	17.9	29.4	25.86		45.4	37.2
		2d	50.8	24.3	30.1	26.11		58.1	49.9
		2.5d	63.5	30.6				70.8	62.6
1"-12	2.117	1d	25.4	9.7			26	33.9	24.3
		1.5d	38.1	15.1	29.7	25.86		46.6	37.0
		2d	50.8	20.6	30.4	26.11		59.3	49.7
		2.5d	63.5	26.1				72.0	62.4
1 1/8"-12	2.117	1d	28.6	10.1			29	37.1	27.5
		1.5d	42.9	17.3	33.2	29.03		51.4	41.8
		2d	57.2	23.4	33.9	29.29		65.7	56.1
1 1/4"-12	2.117	1d	31.8	12.4			32.5	40.3	30.7
		1.5d	47.6	19.3	36.6	32.21		56.1	46.5
		2d	63.5	26.1	37.3	32.46		72.0	62.4
1 3/8"-12	2.117	1d	34.9	13.8			35.5	43.4	33.8
		1.5d	52.4	21.3	40.0	35.38		60.9	51.3
		2d	69.9	28.9	40.9	35.63		78.4	68.8
1 1/2"-12	2.117	1d	38.1	15.2			38.5	46.6	37.0
		1.5d	57.2	23.4	43.4	38.56		65.7	56.1
		2d	76.2	31.6	44.3	38.81		84.7	75.1



## 5、英制粗牙惠氏螺纹 (BSW) 钢丝螺套结构尺寸及安装参数

表 (7) 英制粗牙惠氏螺纹 (BSW)

螺纹规格 d×p	螺距 P	螺纹公称长度		圈数 (W)	自由状态 下外径 (Dz) Min Max	安装螺 套的螺 纹底孔 小径 (Ds1) Min. Max.	推荐 钻头 直径 (do)	钻孔 深度 (L3)	未去除安 装柄时螺 栓最大拧 入深度 (L6)
		×d	L1						
1/8"-40	0.635	1d	3.2	3.4	4.0 4.4	3.28 3.43	3.3	5.7	2.8
		1.5d	4.8	5.6				7.3	4.4
		2d	6.4	7.9				8.9	6.0
		2.5d	7.9	10.3				10.4	7.5
3/16"-24	1.058	1d	4.8	2.9	6.1 6.5	4.98 5.13	5.0	7.8	4.3
		1.5d	7.1	5.1				10.1	6.6
		2d	9.6	6.1				12.6	9.1
		2.5d	11.9	9.3				14.9	11.4
1/4"-20	1.270	1d	6.4	3.4	7.9 8.4	6.63 6.78	6.7	9.9	5.8
		1.5d	9.5	5.9				13.0	8.9
		2d	12.7	8.1				16.2	12.1
		2.5d	15.9	10.5				19.4	15.3
5/16"-18	1.411	1d	7.9	4.1	9.7 10.2	8.33 8.48	8.4	11.4	7.2
		1.5d	11.9	6.7				15.4	11.2
		2d	15.9	9.4				19.4	15.2
		2.5d	19.8	12.0				23.3	19.1
3/8"-16	1.588	1d	9.5	4.5	11.5 12.0	9.91 10.11	10.0	13.5	8.7
		1.5d	14.3	7.3				18.3	13.5
		2d	19.1	10.2				23.1	18.3
		2.5d	23.8	13.0				27.8	23.0
7/16"-14	1.814	1d	11.1	4.6	13.5 14.0	11.51 11.76	11.6	15.1	10.2
		1.5d	16.7	7.5				20.7	15.8
		2d	22.2	10.4				26.2	21.3
		2.5d	27.8	13.3				31.8	26.9
1/2"-12	2.117	1d	12.7	4.4	15.4 16.0	13.08 13.34	13.2	17.7	11.6
		1.5d	19.1	7.3				24.1	18.0
		2d	25.4	10.1				30.4	24.3
		2.5d	31.8	13.0				36.8	30.7
9/16"-12	2.117	1d	14.3	5.2	17.0 17.6	14.68 14.94	14.8	19.3	13.2
		1.5d	21.5	8.4				26.5	20.4
		2d	28.6	11.6				33.6	27.5
		2.5d	35.7	14.8				40.7	34.6
5/8"-11	2.309	1d	15.9	5.4	18.9 19.5	16.59 16.84	16.7	20.9	14.7
		1.5d	23.8	8.7				28.8	22.6
		2d	31.8	11.9				36.8	30.6

		2.5d	39.7	15.3				44.7	38.5
11/16"-1 1	2.309	1d	17.5	6.1	20.5	18.21	18.3	22.5	16.3
		1.5d	26.2	9.7				31.2	25.0
		2d	34.9	13.3				39.9	33.7
		2.5d	43.6	16.9				48.6	42.4
3/4"-10	2.54	1d	19.1	6.0	22.4	19.84	19.9	25.1	17.8
		1.5d	28.6	9.6				34.6	27.3
		2d	38.1	13.2				44.1	36.8
		2.5d	47.6	16.8				53.6	46.3
7/8"-9	2.822	1d	22.2	6.4	26.0	23.01	23.1	28.2	20.8
		1.5d	33.3	10.1				39.3	31.9
		2d	44.5	13.9				50.5	43.1
		2.5d	55.6	17.7				61.6	54.2
1"-8	3.175	1d	25.4	6.5	27.7	26.19	26.5	32.4	23.8
		1.5d	38.1	10.3				45.1	36.5
		2d	50.8	14.1				57.8	49.2
		2.5d	63.5	17.9				70.5	61.9

## 6、英制细牙惠氏螺纹 (BSF) 钢丝螺套结构尺寸及安装参数

表 (8) 英制细牙惠氏螺纹 (BSF)

螺纹规格 d×p	螺距 P	螺纹公称长度		圈数 (W)	自由状 态下外 径(Dz) Min Max	安装螺 套的螺 纹底孔 小径 (Ds1) Min. Max.	推荐 钻头 直径 (do)	钻孔 深度 (L3)	未去除安 装柄时螺 栓最大拧 入深度 (L6)
		×d	L1						
3/16"-32	0.794	1d	4.8	4.1	6.0	4.88	4.9	7.3	4.4
		1.5d	7.1	6.8				9.6	6.7
		2d	9.5	9.4				12.0	9.1
		2.5d	11.9	12.1				14.4	11.5
7/32"-28	0.907	1d	5.5	4.3	7.0	5.72	5.8	8.0	5.0
		1.5d	8.3	7.0				10.8	7.8
		2d	11.1	9.8				12.3	10.6
		2.5d	13.9	12.5				15.0	13.4
1/4"-26	0.977	1d	6.4	4.6	7.9	6.53	6.6	9.4	5.9
		1.5d	9.5	7.6				12.5	9.0
		2d	12.7	10.4				15.7	12.2
		2.5d	15.9	13.4				18.9	15.4
9/32"-26	0.977	1d	7.1	5.4	8.7	7.32	7.4	10.1	6.6
		1.5d	10.7	8.7				13.7	10.2
		2d	14.3	11.9				17.3	13.8
		2.5d	17.9	15.3				20.9	17.4
5/16"-22	1.155	1d	7.9	5.0	9.8	8.20	8.3	11.9	7.3

		1.5d	11.9	8.1	10.3	8.38		15.9	11.3
		2d	15.9	11.2				19.9	15.3
		2.5d	19.8	14.3				23.8	19.2
3/8"-20	1.270	1d	9.5	5.6			9.8	14.0	8.8
		1.5d	14.3	9.0	11.6	9.78		18.8	13.6
		2d	19.1	12.4	12.1	9.96		23.6	18.4
		2.5d	23.8	15.8				28.3	23.1
7/16"-18	1.411	1d	11.1	5.9			11.5	15.6	10.4
		1.5d	16.7	9.5	13.6	11.43		21.2	16.0
		2d	22.2	13.1	14.1	11.63		26.7	21.5
		2.5d	27.8	16.6				32.3	27.1
1/2"-16	1.588	1d	12.7	6.1			13.1	17.7	11.9
		1.5d	19.1	9.7	15.5	13.03		24.1	18.3
		2d	25.4	13.3	16.0	13.26		30.4	24.6
		2.5d	31.8	16.9				36.8	31.0
9/16"-16	1.588	1d	14.3	7.0			14.7	19.3	13.5
		1.5d	21.5	11.1	17.2	14.66		26.5	20.7
		2d	28.6	15.1	17.8	14.88		33.6	27.8
		2.5d	35.7	19.3				30.7	34.9
5/8"-14	1.814	1d	15.9	6.8			16.3	21.9	15.0
		1.5d	23.8	10.8	19.1	16.26		29.8	22.9
		2d	31.8	14.8	19.7	16.49		37.8	30.9
		2.5d	39.7	18.7				45.7	38.8
3/4"-12	2.117	1d	19.1	7.0			19.5	25.1	18.0
		1.5d	28.6	11.1	22.9	19.43		34.6	27.5
		2d	38.1	15.2	23.5	19.69		44.1	37.0
		2.5d	47.6	19.3				53.6	46.5
7/8"-11	2.309	1d	22.2	7.6			22.7	28.2	21.0
		1.5d	33.3	11.9	26.5	22.61		39.3	32.1
		2d	44.5	16.4	27.3	22.86		50.5	43.3
		2.5d	55.6	20.8				61.6	54.4
1"-10	2.540	1d	25.4	7.9			26.2	32.4	24.1
		1.5d	38.1	12.5	30.2	26.19		45.1	36.8
		2d	50.8	17.1	31.0	26.52		57.8	49.5
		2.5d	63.5	21.6				70.5	62.6

## 7、英制管螺纹 (G) 钢丝螺套结构尺寸及安装参数

表 (9) 英制管螺纹 (G)

螺纹规格 d×p	螺距 P	螺纹公称长度		圈数 (W)	自由状态 下外径 (Dz) Min Max	安装螺 套的螺 纹底孔 小径 (Ds1) Min.	推荐 钻头 直径 (do)	钻孔 深度 (L3)	未去除安 装柄时螺 栓最大拧 入深度 (L6)
		×d	L1						

						Max.			
G1/8"-28	0.907	1d	3.2	1.9	11.5	9.91	10.0	5.5	2.7
		1.5d	4.8	3.6				7.31	4.3
		2d	6.4	5.1				8.7	5.9
		2.5d	7.9	6.6				10.2	7.4
G1/4"-19	1.337	1d	6.4	3.1	15.7	13.46	13.5	10.0	5.7
		1.5d	9.5	5.3				13.0	8.8
		2d	12.7	7.4				16.2	12.0
		2.5d	15.9	9.6				19.4	15.2
G3/8"-19	1.337	1d	9.5	5.3	19.5	17.02	17.1	13.0	8.8
		1.5d	14.3	8.5				17.8	13.6
		2d	19.1	11.8				22.6	18.4
		2.5d	23.8	15.0				28.3	23.1
G1/2"-14	1.841	1d	12.7	5.2	24.6	21.34	21.5	18.2	11.7
		1.5d	19.1	8.4				24.6	18.1
		2d	25.4	11.6				25.2	21.59
		2.5d	31.8	14.8				37.3	30.8
G5/8"-14	1.841	1d	15.9	6.8	26.7	23.24	23.4	21.4	14.9
		1.5d	23.8	10.8				27.4	23.55
		2d	31.8	14.8				37.3	30.8
		2.5d	39.7	18.8				45.2	38.7
G3/4"-14	1.841	1d	19.1	8.4	30.5	26.75	26.8	24.6	18.1
		1.5d	28.6	13.3				31.2	27.08
		2d	38.1	18.1				43.6	37.1
		2.5d	47.6	22.9				53.1	46.6
G7/8"-14	1.841	1d	22.2	10.0	34.6	30.48	30.6	27.7	21.2
		1.5d	33.3	15.6				35.3	30.81
		2d	44.5	21.3				50.0	43.5
		2.5d	55.6	27.0				91.1	54.6
G1"-11	2.309	1d	25.4	8.9	38.4	33.53	33.7	31.4	24.3
		1.5d	38.1	13.9				39.2	33.91
		2d	50.8	19.0				56.8	49.7
		2.5d	63.5	24.0				69.5	62.4

### 8、公制无尾钢丝螺套结构尺寸及安装参数

表 (10) 公制无尾钢丝螺套

公称直径 (d)	螺距 (P)	公称长度		圈数 (W)	自由状态下 外径 (Dz) Min. Max.	安装螺套的 螺纹底孔小径 (Ds1) Min. Max.	推荐钻头直径 (do)	钻孔深度 (L3)
		xd	L <sub>1</sub>					
2.5	0.45	1d	2.5	3.4	3.20	2.60	2.6	4.3

		1.5d	3.75	5.6	3.35	2.70		5.6
		2d	5.0	8.0				6.8
3	0.5	1d	3.0	3.8	3.80 3.99	3.11 3.22	3.1	5.0
		1.5d	4.5	6.4				6.5
		2d	6.0	8.9				8.0
4	0.7	1d	4.0	3.6	5.05 5.28	4.15 4.29	4.2	6.8
		1.5d	6.0	6.1				8.8
		2d	8.0	8.6				10.8
5	0.8	1d	5.0	4.1	6.2 6.50	5.17 5.33	5.2	8.2
		1.5d	7.5	6.9				10.7
		2d	10.0	9.6				13.2
6	1	1d	6.0	4.0	7.4 7.78	6.22 6.41	6.3	9.0
		1.5d	9.0	6.8				12.0
		2d	12.0	9.5				13.0
8	1.25	1d	8.0	4.5	9.8 10.18	8.27 8.48	8.3	12.0
		1.5d	12.0	7.4				16.0
		2d	16.0	10.3				20.0
10	1.5	1d	10.0	5.0	11.95 12.41	10.32 10.56	10.4	14.0
		1.5d	15.0	8.1				20.0
		2d	20.0	11.2				25.0
12	1.75	1d	12.0	5.2	14.30 14.80	12.38 12.64	12.4	17.0
		1.5d	18.0	8.4				23.0
		2d	24.0	11.7				29.0

### 9、美制统一螺纹无尾钢丝螺套结构尺寸及安装参数

表 (11) 美制统一螺纹无尾钢丝螺套

螺纹规格 d×p	螺距 P	螺纹公称长度		圈数 (W)	自由状态下 外径(Dz) Min Max	安装螺套 的螺纹底 孔小径 (Ds1) Min. Max.	推荐钻 头 直径 (do)	钻孔 深度 (L3)
		×d	L1					
2-56 (0.086)	0.454	1d	2.18	3.0	2.8 3.0	2.28 2.44	2.4	3.9
		1.5d	3.28	5.25				5.0
		2d	4.37	7.4				6.1
4-40 (0.112)	0.635	1d	2.84	2.8	3.66 4.04	3.0 3.15	3.1	5.4
		1.5d	4.27	4.8				6.8

		2d	5.69	6.8				8.3
6-32 (0.138)	0.794	1d	3.5	2.8	4.52	3.68	3.8	6.7
		1.5d	5.26	4.8				8.5
		2d	7.01	6.9				10.2
8-32 (0.164)	0.794	1d	4.17	3.5	5.2	4.34	4.4	6.4
		1.5d	6.25	6.0				8.5
		2d	8.33	8.4				10.5
10-32 (0.19)	0.794	1d	4.83	4.1	6.0	5.0	5.1	7.0
		1.5d	7.24	6.9				9.1
		2d	9.65	9.5				11.1
10-24 (0.19)	1.058	1d	4.83	2.9	6.2	5.06	5.2	8.0
		1.5d	7.24	5				10.4
		2d	9.65	7.1				12.8
1/4"-28	1.058	1d	6.35	5	7.77	6.55	6.7	9.0
		1.5d	9.5	8.3				12.1
		2d	12.7	11.4				15.3
1/4"-20	1.27	1d	6.35	6.6	7.88	6.62	6.7	10.5
		1.5d	9.5	9.52				13.6
		2d	12.7	12.7				16.8
5/16"-18	1.411	1d	7.92	4.0	9.65	8.24	8.4	12.5
		1.5d	11.9	6.6				16.5
		2d	15.88	9.3				20.5
5/16"-24	1.058	1d	7.92	5.5	9.65	8.17	8.2	12.1
		1.5d	11.9	8.9				16.1
		2d	15.88	12.3				20.1
3/8"-16	1.588	1d	9.52	4.4	11.48	9.89	10	14.9
		1.5d	14.27	7.3				29.7
		2d	19.05	10				24.5
3/8"-24	1.058	1d	9.52	6.9	11.38	9.75	9.8	11.7
		1.5d	14.27	11				16.5
		2d	19.05	15				21.3

#### 四、钢丝螺套专用丝锥

钢丝螺套专用丝锥用于加工钢丝螺套安装孔的专用内螺纹，结构尺寸依照国家标准《细柄机用和手用丝锥》GB3464-83 等要求制造，材料为 W6Mo5Cr4V2，可机用也可手用，根据其使用范围可分为轻合金机、手用丝锥、普通钢机、手用丝锥，特种丝锥三种。

##### 1、轻合金机、手用丝锥

用于加工铝、镁合金以及铜合金等有色金属合金。

标记方法:

STd×P ST 为钢丝螺套专用内螺纹代号。

标记示例：

用在于轻合金上加工安装规格为 8×1.25 钢丝螺套底孔螺纹的专用丝锥，标记为：  
ST8×1.25

## 2、普通钢机、手用丝锥

用于加工钢、铸铁、铸钢等金属材料上的内螺纹，是成付丝锥。

## 3、特种丝锥

可根据用户需要设计、制造各种特殊品种的螺纹底孔丝锥，例如在软铝、紫铜上攻丝的机用挤压丝锥、不锈钢攻丝丝锥、盲孔的平底丝锥、螺旋槽丝锥、螺尖丝锥等。

# 五、钢丝螺套安装扳手

钢丝螺套扳手用于钢丝螺套在螺纹底孔内的安装，其基本原理是使钢丝螺套通过一段引导螺纹，迫使外径收缩，以便顺利装入底孔。

## 1、手动安装扳手

(1) 按螺母型分类：

A、组合螺母型手动安装扳手；B、整体螺母型手动安装扳手

(2) 按扳手前端形状分类：

A、T型槽手动扳手；B、螺纹头型手动安装扳手

## 2、自动安装扳手

自动安装扳手有气动、电动两种，具有高效、快速、安装定位准确的特点，用于批量钢丝螺套的安装或在装配生产线上使用。

## 3、无尾螺套安装扳手

无尾螺套的安装使用无尾螺套专用安装扳手

# 六、钢丝螺套安装柄去除工具

冲断器：利用瞬间冲力折断钢丝螺套安装柄。

# 七、钢丝螺套拆卸工具

卸套器：用于取出安装在底孔内螺纹中的钢丝螺套。

# 八、钢丝螺套专用内螺纹塞规

用于检验钢丝螺套安装底孔的内螺纹，分为单头整体塞规及双头插柄塞规。

## 1、单头整体塞规

用于检验 m2~m5 小规格钢丝螺套安装前内孔螺纹。

## 2、双头插柄塞规

用于检验 m5 以上规格钢丝螺套安装前内孔螺纹。

# 九、钢丝螺套的安装过程

钢丝螺套安装由钻孔、攻丝、安装螺套、去除安装柄四个主要步骤组成。

## 1、钻孔

用表中所列直径  $d_0$  的标准钻头钻孔，钻孔直径符合  $D_{s1}$  尺寸要求，钻孔深度要大于或等于  $1_2$ ；切屑不要掉入可能会引起损坏的地方。钻孔后允许去毛刺性质的铤孔，铤孔不应超过  $0.4P$  深度，因为过大的铤孔不利于钢丝螺套的导入而造成安装困难。



## 2、攻丝

使用标有规定螺纹规格的钢丝螺套专用丝锥攻丝，攻丝的长度必须超过钢丝螺套长度，对于通孔要全部攻丝；攻丝的精度决定最终标准内螺孔的精度，使用者要适当地选择攻丝方法和润滑，盲孔攻丝要用力适当，以防折断丝锥。



攻丝后，螺纹孔应清理，一般用压缩空气喷枪吹，盲孔时还应使用带径向孔的长喷枪自下而上清理，也可以用清洗的方法清理螺纹孔；攻丝完成后应该使用专用钢丝螺套底孔内螺纹塞规进行精度检查。

## 3、安装螺套

在一般情况下应用手动安装扳手进行钢丝螺套安装。

钢丝螺套放入安装扳手内，使安装柄嵌入导杆槽内转动安装扳手手柄，使钢丝螺套旋入螺孔，并使其距基体表面留有  $0.75\sim 1.5P$  的空螺纹。





少量安装钢丝螺套时和  $14 \times 2$  以上粗牙钢丝螺套安装时，可采用“T”型开槽或螺纹头简易工具安装。并注意不要在钢丝螺套安装柄上施加较大的轴向力以防“乱扣”。

在流水线装配或要求快速安装钢丝螺套的情况下，使用电动或气动的半自动的安装扳手，以获得快速、可靠的安装。

钢丝螺套安装后，可用相应的级别塞规，检验所形成的标准内螺纹孔精度等级。

#### 4、去除安装柄

通孔时，要将钢丝螺套安装柄折断，一般用于冲断器对准安装柄，用 200g 左右的榔头猛打一下即可去除，对于  $18 \times 2.5$  以上的粗牙钢丝螺套和  $14 \times 1.25$  以上的细牙钢丝螺套，用尖嘴钳上下弯曲安装柄就能从开槽处折断。



#### 5、取出钢丝螺套

在安装过程中出现问题或者由于钢丝螺套使用时间过长需要取出钢丝螺套，应当使用锥形带有刃口的卸套工具，对准手柄，用榔头猛打一下，用手加力按下手柄反螺纹方向旋转，即可取出钢丝螺套。

公司名称：新乡市中冠机械有限公司

地 址：河南省新乡市新飞大道南段 1018 号新乡科技产业园区 A4a 号

电 话：0373—2686995 15837387867

0373—5036376 15517311756

0373—2686996 13937366078

传 真：0373—3866533 商务 QQ：3163469217

网 址：<http://www.zhongguangongye.com>

E—mail：[xxzg87867@126.com](mailto:xxzg87867@126.com) [3163469217@qq.com](mailto:3163469217@qq.com)

